

OUR CUSTOMERS

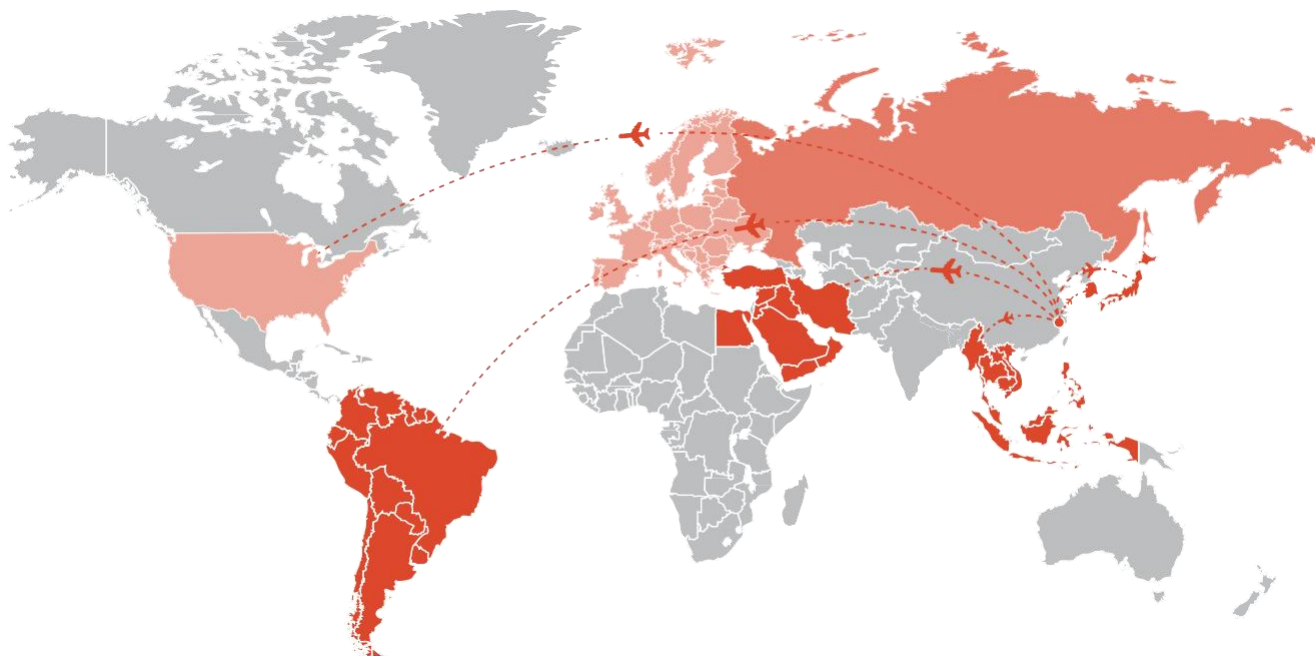

HAIER | SUPOR | QUANTA | NIKAI | MONDIAL

LETTON | BOMANN | GEEPAS | KURUMI | AMTOK

Contents

目录 >

03-04 **手持挂烫机系列**
Handheld Garment Steamer

05-06 **立式挂烫机系列**
Stand Garment Steamer

07-11 **除螨仪系列**
Mite Vacuum Cleaner

12-13 **电动拖把系列**
Electric Mop

14 **吸尘器系列**
Vacuum Cleaner

HANDHELD GARMENT STEAMER

手持挂烫机

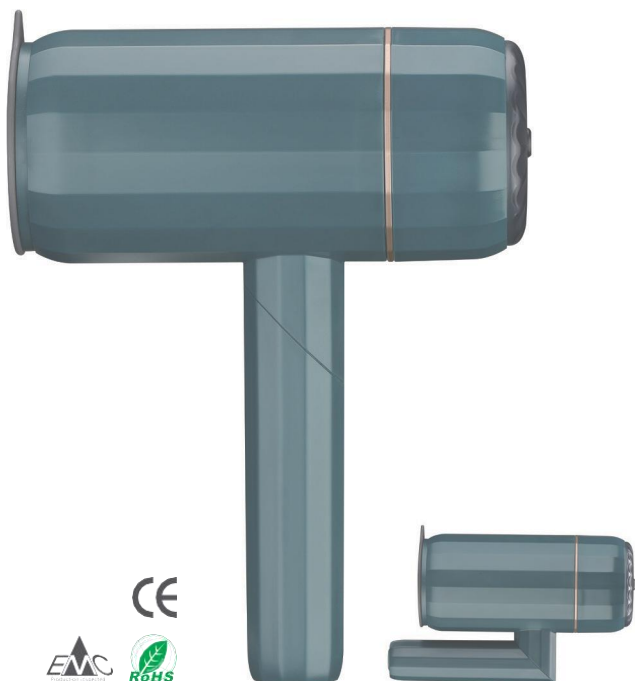

型号 MODEL **KG1807**

额定功率 Power:	1200W
额定电压 Voltage:	220V-240V
蒸汽量 Steam rate:	16±4g/min
电源线长 Cord Length:	1.8 meters
水箱容量 Water Tank:	140ml
输出时间 Preheating time:	30s
运行时间 Working time:	8mins
产品尺寸 Product Size(MM):	200*125*85
箱子尺寸 Box Size(MM):	270*170*118
净重/毛重 N. W. /G. W. :	0.68KG/1KG
20/40/40英尺高柜 20' /40' /40HQ:	5400/11000/17000

型号 MODEL **KG1808A**

额定功率 Power:	1200W
额定电压 Voltage:	220V-240V
蒸汽量 Steam rate:	21±4g/min
电源线长 Cord Length:	1.8 meters
水箱容量 Water Tank:	230ml
输出时间 Preheating time:	30s
运行时间 Working time:	10mins
产品尺寸 Product Size(MM):	223*158*120
箱子尺寸 Box Size(MM):	260*195*140
	1.29KG/1.6KG
20/40/40英尺高柜 20' /40' /40HQ:	2700/5600/6300



HANDHELD GARMENT STEAMER

手持挂烫机



型号 MODEL **KG1808**

额定功率 Power:	1200W
额定电压 Voltage:	220V-240V
蒸汽量 Steam rate:	21±4g/min
电源线长 Cord Length:	1.8 meters
水箱容量 Water Tank:	250ml
输出时间 Preheating time:	30s
运行时间 Working time:	12mins
产品尺寸 Product Size(MM):	223*158*120
箱子尺寸 Box Size(MM):	260*195*140
净重/毛重 N.W./G.W.:	1.4KG/1.7KG
20/40/40英尺高柜 20' /40' /40HQ:	2700/5600/6300

型号 MODEL **KG1809**

额定功率 Power:	1200W
额定电压 Voltage:	220V-240V
蒸汽量 Steam rate:	21±4g/min
电源线长 Cord Length:	1.8 meters
水箱容量 Water Tank:	250ml
输出时间 Preheating time:	30s
运行时间 Working time:	10mins
产品尺寸 Product Size(MM):	160*120*300
箱子尺寸 Box Size(MM):	340*217*143
	1.29KG/1.6KG
20/40/40英尺高柜 20' /40' /40HQ:	2700/5600/6300



STAND GARMENT STEAMER

立式挂烫机



型号 MODEL

KG3203

额定功率 Power:	1800W
额定电压 Voltage:	220V-240V
蒸汽量 Steam rate:	30±2g/min
电源线长 Cord Length:	1.7 meters
水箱容量 Water Tank:	1.8L
输出时间 Preheating time:	30s
运行时间 Working time:	60mins
可调高度 Adjustable Height: :	75CM/110CM/150CM
基本尺寸 The Base Size (MM) :	200*210*330
箱子尺寸 Box Size (MM):	385*330*445
净重/毛重 N. W/G. W. :	3.7KG/4.7KG
20/40/40英尺高柜 20' /40' /40HQ:	525/1085/1300
	2steam control level

型号 MODEL

KG3203L

额定功率 Power:	1800W
额定电压 Voltage:	220V-240V
蒸汽量 Steam rate:	30±2g/min
电源线长 Cord Length:	1.7 meters
水箱容量 Water Tank:	1.8L
输出时间 Preheating time:	30s
运行时间 Working time:	60mins
可调高度 Adjustable Height: :	75CM/110CM/150CM
基本尺寸 The Base Size (MM) :	200*210*330
箱子尺寸 Box Size (MM):	385*330*445
	3.7KG/4.7KG
20/40/40英尺高柜 20' /40' /40HQ:	525/1085/1300
	2steam control level



STAND GARMENT STEAMER

立式挂烫机



CB

型号 MODEL **KG3208**

额定功率 Power:	2000W
额定电压 Voltage:	220V-240V
蒸汽量 Steam rate:	30±2g/min
电源线长 Cord Length:	1.7 meters
水箱容量 Water Tank:	1.7L
输出时间 Preheating time:	30s
运行时间 Working time:	55mins
可调高度 Adjustable Height::	75CM/110CM/150CM
基本尺寸 The Base Size(MM):	320*210*280
箱子尺寸 Box Size(MM):	446*308*416
净重/毛重 N. W/G. W.:	5.3KG/6.2KG
20/40/40英尺高柜 20' /40' /40HQ:	475/975/1170

2steam control level

型号 MODEL **KG3209**

额定功率 Power:	2000W
额定电压 Voltage:	220V-240V
蒸汽量 Steam rate:	30±2g/min
电源线长 Cord Length:	1.7 meters
水箱容量 Water Tank:	2L
输出时间 Preheating time:	30s
运行时间 Working time:	65mins
可调高度 Adjustable Height::	75CM/110CM/150CM
基本尺寸 The Base Size(MM):	260*260*260
箱子尺寸 Box Size(MM):	503*363*390
净重/毛重 N. W/G. W.:	5.9KG/6.8KG
20/40/40英尺高柜 20' /40' /40HQ:	380/800/990

10steam control levels



CB

MITE VACUUM CLEANER

除螨仪



型号 MODEL **KL2010AC**

额定功率 Power:	350w
真空度 Suction:	10kPa
电源线长Cord Length:	3m
紫外线长UV Length:	253.7mm
集尘容量Dust box capacity:	0.25L
拍打频率Dusting Function:	8000/mins
产品尺寸Product Size(MM):	250*230*130
箱子尺寸Box Size(MM):	292*183*300
净重/毛重N. W/G. W.:	1.2KG/1.5KG
20/40/40英尺高柜20' /40' /40HQ:	1820/3700/4700

型号 MODEL **SC3905**

额定功率 Power:	300W
真空度 Suction:	10kPa
电源线长Cord Length:	3m
紫外线长UV Length:	253.7mm
集尘容量Dust box capacity:	0.4L
拍打频率Dusting Function:	6400/mins
产品尺寸Product Size(MM):	353*251*154
箱子尺寸Box Size(MM):	290*190*385
	1.4KG/1.8KG
20/40/40英尺高柜20' /40' /40HQ:	1440/2900/3400



MITE VACUUM CLEANER

除螨仪



型号 MODEL **SC2905**

额定功率 Power:	300W
真空度 Suction:	8kPa
电源线长 Cord Length:	3m
紫外线长 UV Length:	253.7mm
集尘容量 Dust box capacity:	0.4L
拍打频率 Dusting Function:	8000/mins
产品尺寸 Product Size(MM):	320*260*230
箱子尺寸 Box Size(MM):	270*165*375
	1.2KG/1.7KG

型号 MODEL

SC2905A

额定功率 Power:	300W
真空度 Suction:	8kPa
电源线长 Cord Length:	3m
紫外线长 UV Length:	253.7mm
集尘容量 Dust box capacity:	0.4L
拍打频率 Dusting Function:	8000/mins
产品尺寸 Product Size(MM):	250*350*140
箱子尺寸 Box Size(MM):	300*405*155
净重/毛重 N. W./G. W. :	1.36KG/1.7KG
20/40/40英尺高柜 20' /40' /40HQ:	1400/3000/3400



CE CB

MITE VACUUM CLEANER

除螨仪



型号 MODEL **SC3901**

额定功率 Power:	300W
真空度 Suction:	8kPa
电源线长 Cord Length:	3m
紫外线长 UV Length:	253.7mm
集尘容量 Dust box capacity:	0.5L
拍打频率 Dusting Function:	8000/mins
产品尺寸 Product Size (MM):	250*320*160
箱子尺寸 Box Size (MM):	290*325*220
净重/毛重 Net Weight/Gross Weight:	1.27KG/1.6KG

型号 MODEL **SC3903**

额定功率 Power:	300W
真空度 Suction:	8kPa
电源线长 Cord Length:	3m
紫外线长 UV Length:	253.7mm
集尘容量 Dust box capacity:	0.5L
拍打频率 Dusting Function:	8000/mins
产品尺寸 Product Size (MM):	250*320*160
箱子尺寸 Box Size (MM):	290*325*220
净重/毛重 Net Weight/Gross Weight:	1.27KG/1.6KG
20/40/40英尺高柜 20' / 40' / 40HQ:	1400/2800/3400



▶ MITE VACUUM CLEANER 除螨仪



型号 MODEL

S1

额定功率 Power:	400w
真空度 Suction:	10kPa
电源线长 Cord Length:	3m
紫外线长 UV Length:	253.7mm
集尘容量 Dust box capacity:	0.5L
拍打频率 Dusting Function:	8000/mins
产品尺寸 Product Size(MM):	312*160*295
箱子尺寸 Box Size(MM):	370*330*200
净重/毛重 N. W/G. W.:	1.75KG/2.9KG

型号 MODEL

KL2010DC

额定功率 Power:	140W
真空度 Suction:	7kPa
紫外线长 UV Length:	253.7mm
电池容量 Battery Capacity:	2200mAh
集尘容量 Dust box capacity:	0.25L
拍打频率 Dusting Function:	8000/mins
运行时间 Working time:	Standard 45 Strong level 20mins
产品尺寸 Product Size(MM):	250*230*130
箱子尺寸 Box Size(MM):	292*183*300
净重/毛重 N. W/G. W.:	1.4KG/1.7KG
20/40/40英寸高柜 20' / 40' / 40HQ:	800/1650/1900



MITE VACUUM CLEANER

除螨仪



型号 MODEL **SC2903R**

额定功率 Power:	120W
真空度 Suction:	5kPa
紫外线长UV Length:	253.7mm
电池容量Battery Capacity:	2200mAh
集尘容量Dust box capacity:	0.5L
拍打频率Dusting Function:	8000/mins
运行时间Working time:	Standard level 45mins Strong level 25mins
产品尺寸Product Size(MM):	330*175*295
箱子尺寸Box Size(MM):	360*250*320
净重/毛重N. W/G. W. :	1.6KG/2.5KG
20/40/40英尺高柜20' /40' /40HQ:	1000/2050/2300

型号 MODEL **SC2907**

额定功率 Power:	120W
真空度 Suction:	7kPa
紫外线长UV Length:	253.7mm
电池容量Battery Capacity:	2200mAh
集尘容量Dust box capacity:	0.5L
拍打频率Dusting Function:	8000/mins
运行时间Working time:	Standard level 45mins Strong level 20mins
产品尺寸Product Size(MM):	300*300*200
箱子尺寸Box Size(MM):	400*300*280
净重/毛重N. W/G. W. :	1.55KG/2.2KG
20/40/40英尺高柜20' /40' /40HQ:	800/1650/1900



ELECTRIC MOP

电动拖把



型号 MODEL MY-1902

额定功率 Power:	25W
额定电压 Voltage:	7.4V
旋转速度 Revolving Speed:	110rpm
电池容量 Battery Capacity:	2000mAh
持续时间 Duration:	DRY (90min) WET (60min)
适配器 Adapter:	IN 220V 50HZ OUT 9V DC 500mA
净重/毛重 N. W/G. W. :	1KG/1.5KG
	1085*285*300
包装尺寸 Size of Package (MM):	473*95*170
20/40/40英寸高柜 20' /40' /40HQ:	3500/7000/8500

型号 MODEL MY-1902W

额定功率 Power:	25W
额定电压 Voltage:	7.4V
旋转速度 Revolving Speed:	110rpm
电池容量 Battery Capacity:	2000mAh
持续时间 Duration:	DRY (90min) WET (60min)
水箱容量 Water Box Capacity:	240ml
	IN 220V 50HZ OUT 9V DC 500mA
净重/毛重 N. W/G. W. :	1.1KG/1.6KG
产品尺寸 Size of Product (MM):	1085*285*300
包装尺寸 Size of Package (MM):	490*105*180
20/40/40英寸高柜 20' /40' /40HQ:	3500/7000/8500



ELECTRIC MOP

电动拖把



型号 MODEL MY-1903A

额定功率 Power:	45W
额定电压 Voltage:	11.1V
旋转速度 Revolving Speed:	160rpm
电池容量 Battery Capacity:	2200mAh
持续时间 Duration:	DRY (90min) WET (60min)
水箱容量 Water Box Capacity:	180ml
适配器 Adapter:	IN 220V 50HZ OUT 17.5V DC 650mA
净重/毛重 N. W/G. W. :	2.5KG/2.9KG
	1185*165*330
包装尺寸 Size of Package (MM):	420*130*370
20/40/40英尺高柜 20' /40' /40HQ:	1100/2400/3000

型号 MODEL MY-1903B

额定功率 Power:	45W
额定电压 Voltage:	11.1V
旋转速度 Revolving Speed:	160rpm
电池容量 Battery Capacity:	2200mAh
持续时间 Duration:	DRY (90min) WET (60min)
水箱容量 Water Box Capacity:	180ml
适配器 Adapter:	IN 220V 50HZ OUT 17.5V DC 650mA
净重/毛重 N. W/G. W. :	2.5KG/2.9KG
产品尺寸 Size of Product (MM):	1185*165*330
包装尺寸 Size of Package (MM):	420*130*370



VACUUM CLEANER

吸尘器



型号 MODEL **LF-11**

额定功率 Power:	600W
真空度 Suction:	15kPa
电源线长 Cord Length:	5m
集尘容量 Dust box capacity:	1.2L
产品尺寸 Product Size(MM):	260*288*1123
箱子尺寸 Box Size(MM):	470*270*240
净重/毛重 N. W/G. W. :	2KG/2.5KG
20/40/40英尺高柜 20' /40' /40HQ:	1000/2050/2400

型号 MODEL **LF-12**

额定功率 Power:	400W
真空度 Suction:	14kPa
电源线长 Cord Length:	5m
集尘容量 Dust box capacity:	1.0L
产品尺寸 Product Size(MM):	260*288*1123
箱子尺寸 Box Size(MM):	495*180*205
净重/毛重 N. W/G. W. :	1.39KG/2.5KG
20/40/40英尺高柜 20' /40' /40HQ:	1300/2400/2600

